

Model BIAQWC1

Part of the Overture System - Smart sensors automatically detect temperature, humidity, tVOC's and eCO2 to help control your indoor air quality by activating your ventilation devices to replace stale and polluted air with fresh, clean air.

FEATURES	
Smart Sensors	Detect temperature, humidity, tVOC's, and eCO2
Inputs	120V~, 60 Hz
Outputs	<p>½ HP Motor, 15A Resistive, 15A Inductive, 3A Incandescent, 0.6A Electronic Ballast</p> <p>When used in combination with fan/light fixtures that are switched together, the device is rated for the following lamps: 360W incandescent, 72W LED or 72W CFL</p> <p>For control of electronic ballast, CFL's, LED and LED lamps or equivalent</p> <p>Typical wire sizes: 12AWG (MAX) or 14AWG solid copper wire rated for at least 90°C</p> <p>Operating temperature: 32-95°F (0-35°C)</p>
Connectivity	Requires a 2.4 GHz Wi-Fi network within 100 feet
Compatibility	<p>Works with compatible Broan bath fans, Fresh Air Systems, and ADA-compliant range hoods</p> <p>Can control light and fan independently</p> <p>Pollution Degree 2 product for household environment or similar</p> <p>Fresh Air System required for air exchange</p> <p>Visit www.broan-nutone.com or www.broan.ca for a list of compatible products</p>
SAFETY	
<p>RoHS and Prop. 65 compliant</p> <p>Meets all applicable FCC and Canadian IC requirements</p> <p>FCC ID: 2ADLL-1103434</p> <p>IC ID: 2143B-1103434</p>	
INSTALLATION	
<p>Mounting and Electrical Hardware included</p> <p>Fits single-gang box (minimum 18 cubic inch).</p> <p>#14 AWG wire - use 3" deep electrical box</p> <p>#12 AWG wire - use 3 1/2" electrical box</p> <p>Complete installation instructions included with each unit and available in the app.</p>	

Product made in China

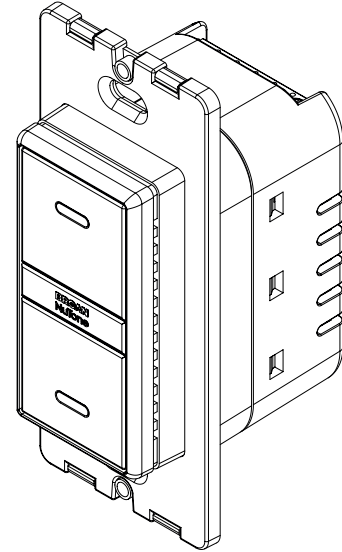

Google Assistant is a trademark of Google Inc.



Amazon, Alexa and all related logos are trademarks of Amazon.com, Inc. or its affiliates.



APPLE is a trademark of Apple Inc., registered in the U.S. and other countries.



Android is a trademark of Google LLC. The Android robot is reproduced or modified from work created and shared by Google and used according to terms described in the Creative Commons 3.0 Attribution License.



Requires a 2.4 GHz Wi-Fi network. App compatible with iOS and Android.



Wireless products featuring Bluetooth® technology. The Bluetooth® word mark and logos are registered trademarks owned by Bluetooth SIG, Inc. and any use of such marks by Broan-NuTone LLC is under license. Other trademarks and trade names are those of their respective owners.



Scan for more info on the Overture™ system



Scan for installation instructions

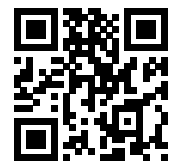

Scan to download the app